

BUZWAIR CRYOGENIC SERVICES

IN

LNG TESTING, NITROGEN
PURGING AND GAS
SUPPLY

LNG TESTING

- GLOBAL TEST / PRIMARY & SECONDARY BARRIERS TIGHTNESS TEST
 - . For testing on the integrity of primary and secondary membranes of GTT membrane containment systems, i.e. MARK III, NO 96, CS1

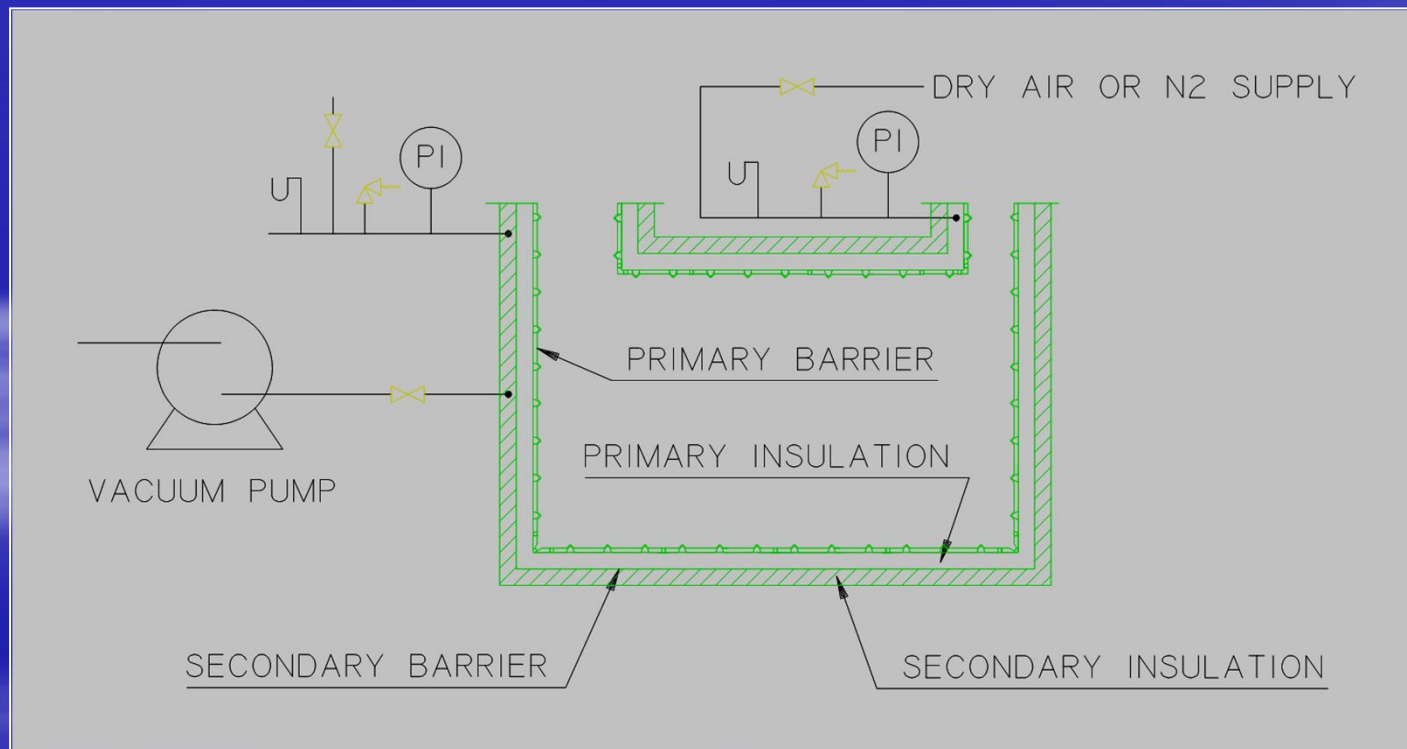

EQUIPMENT USED

GLOBAL TEST CONTROL ROOM (GTCCR)



INSIDE THE GTCR



CHART RECORDER

**CONTROL MANIFOLD
FOR VACUUM-PULLING
AND NITROGEN
INJECTION**

INSIDE THE GTCR

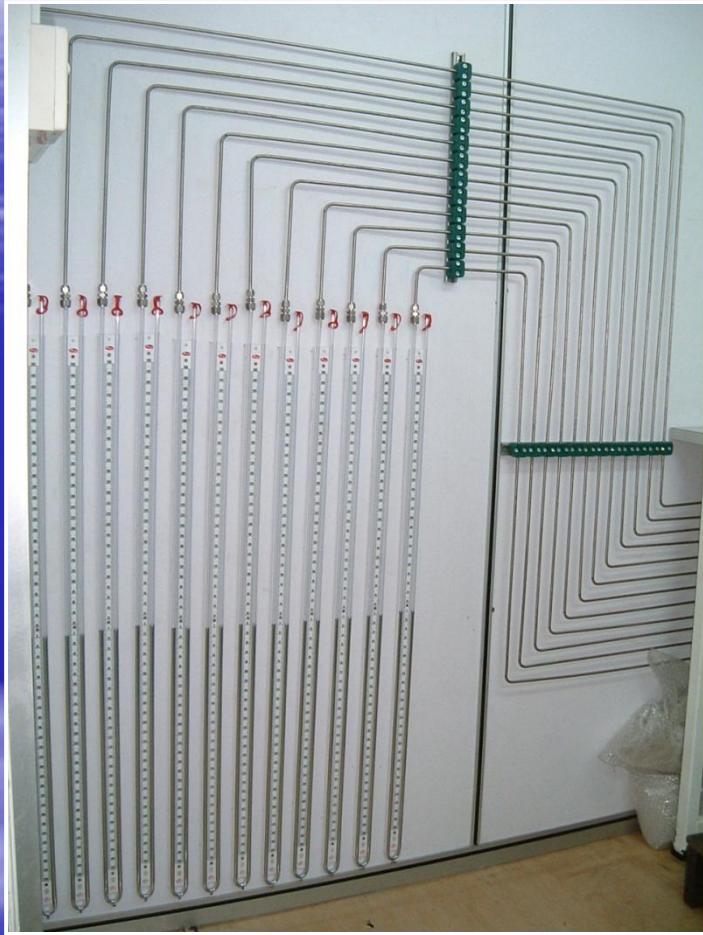

MERCURY U-TUBES



VACUUM PUMPS

GTCR



**HOOKING-UP POINTS FOR INSTRUMENTS,
HOSES, AND ELECTRICAL SUPPLY**

SAMPLE P&ID FOR MARK III

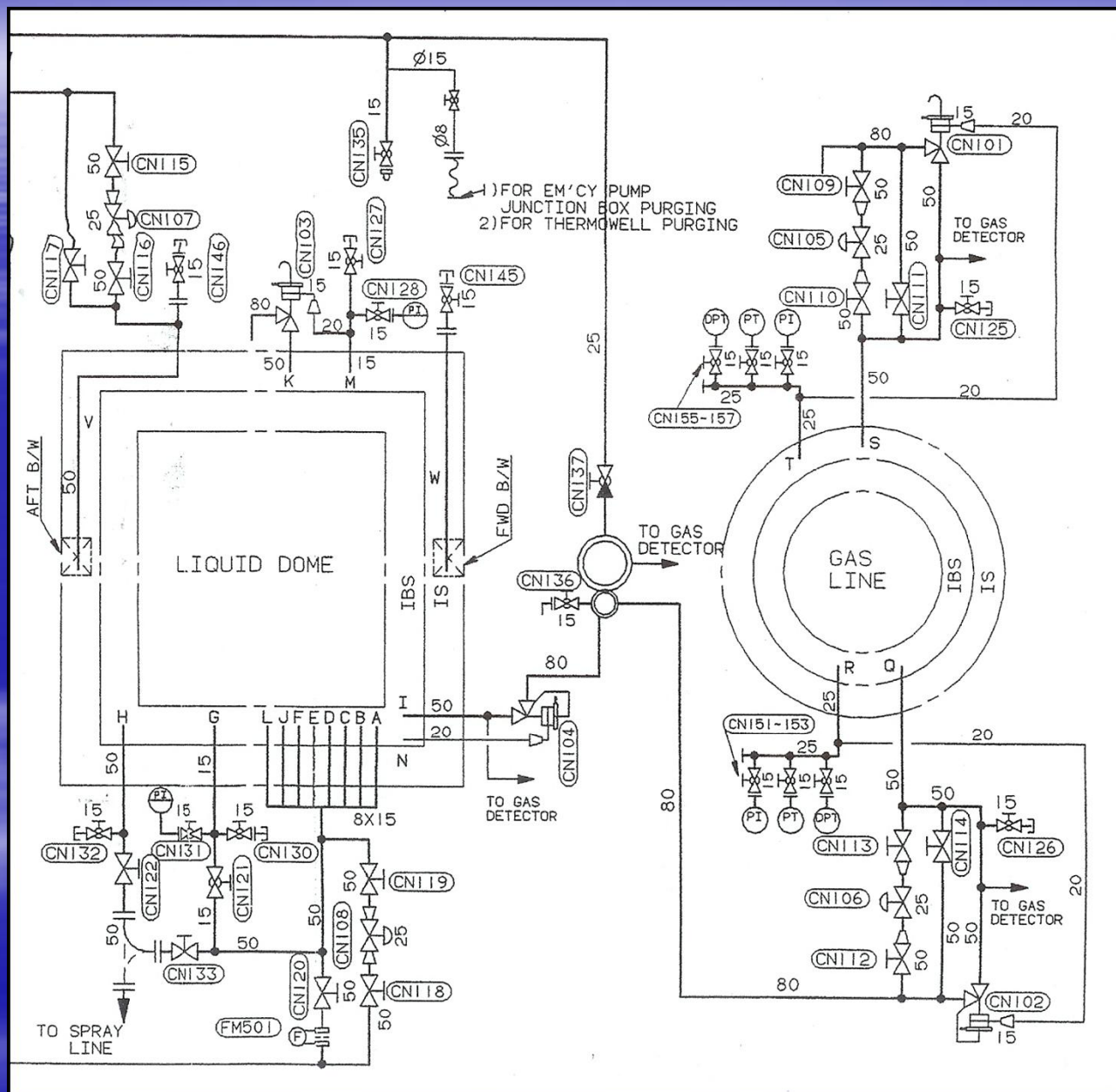

CONNECTION POINTS



VACUUM & N2 HOSES



INSTRUMENTS

SAFETY DEVICE

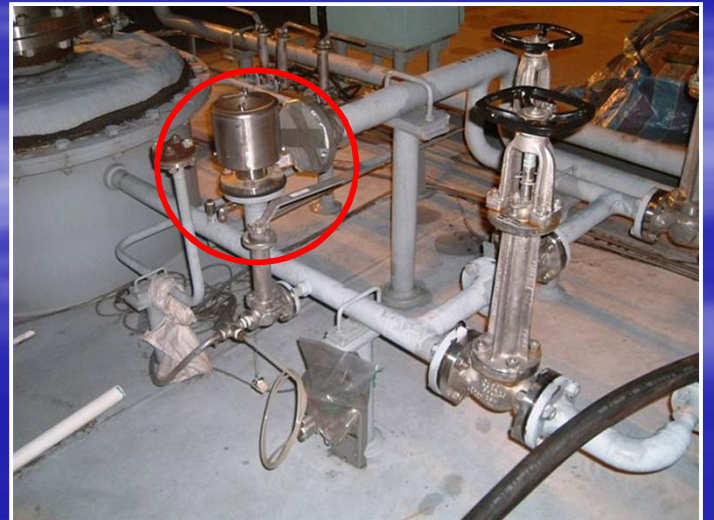

NITROGEN EQUIPMENT



HELIUM LEAK TEST



ACOUSTIC TEST

- ACOUSTIC EQUIPMENT WILL BE BROUGHT IN FROM FRANCE
- SITE MANAGER TO BE AT LEAST LEVEL 2 COFREND
- FINAL REPORT TO BE CHECKED BY AN EXPERT CERTIFIED LEVEL 3 COFREND, WITHIN 3 WEEKS FROM DATE OF SERVICE COMPLETION

NITROGEN PURGING

- TO INERT / GAS-FREE THE CARGO TANKS IN PREPARATION FOR PRODUCT PRE-LOADING, CHANGE OF CARGO OR SHIPYARD DOCKING



NITROGEN PURGING



WATER VAPORIZER



GAS SUPPLY

- WE CAN ALSO SUPPLY THE FOLLOWING PRODUCTS USING OUR ISO TANKS, DRUMS OR CYLINDERS

- . REFRIGERANTS, SUCH AS:

- PROPYLENE
- PROPANE
- AMMONIA
- R22, R134a.

- . CRYOGENIC LIQUIDS, SUCH AS:

- LIQUID NITROGEN
- LIQUID CARBON DIOXIDE